

BUILT-IN DOUBLE OVEN

USER MANUAL

GEDM4700B

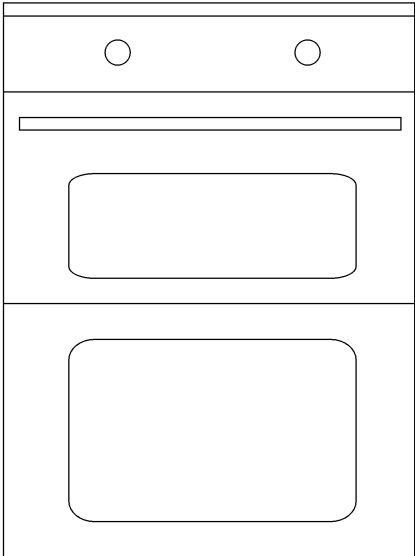

FOR A GOOD REASON
GRUNDIG

Please read this user manual first!

Dear Customer,

Thank you for purchasing this Grundig product. We hope that you get the best results from your product which has been manufactured with high quality and state-of-the-art technology. Therefore, please read this entire user manual and all other accompanying documents carefully before using the product and keep it as a reference for future use. If you handover the product to someone else, give the user manual as well. Follow all warnings and information in the user manual.

Remember that this user manual is also applicable for several other models. Differences between models will be identified in the manual.

Please visit the "Support" section on the Grundig website at www.grundig.co.uk to register your 5 year warranty.

Grundig Helpline

0845 603 1234

0345 603 1234

Explanation of symbols

Throughout this user manual the following symbols are used:



Important information or useful hints about usage.



Warning of hazardous situations with regard to life and property.



Warning of electric shock.



Warning of risk of fire.



Warning of hot surfaces.

CE

1 Important instructions and warnings for safety and environment 4

General safety 4
 Electrical safety 4
 Product safety 5
 Intended use 7
 Safety for children 7
 Disposing of the old product 8
 Package information 8

2 General information 9

Overview 9
 Package contents 10
 Technical specifications 11

3 Installation 12

Before installation 12
 Installation and connection 13
 Future Transportation 15

4 Preparation 16

Tips for saving energy 16
 Initial use 16
 Day time 16
 First cleaning of the appliance 17
 Initial heating 17

5 How to operate the oven 18

General information on baking, roasting and grilling 18

How to operate the electric oven 18
 Operating modes 21
 How to operate the oven control unit 23
 Using the keylock 25
 Using the clock as an alarm 26
 Cooking times table 27
 Ready meals functions 29
 Settings menu 30
 How to operate the grill 31
 Cooking times table for grilling 31
 How to operate the top oven 32
 Operating modes 32
 Cooking times table 33
 How to operate the top grill 34
 Top oven cooking times table for grilling 34

6 Maintenance and care 35

General information 35
 Cleaning the control panel 35
 Cleaning the oven 35
 Removing the oven door 36
 Removing the door inner glass 36
 Removing the top oven door inner glass 37
 Replacing the oven lamp 38

7 Troubleshooting 40

8 Guarantee 41

9 Service 42

1 Important instructions and warnings for safety and environment

This section contains safety instructions that will help protect from risk of personal injury or property damage. Failure to follow these instructions shall void any warranty.

General safety

- This appliance can be used by children aged from 8 years and above and persons with reduced physical, sensory or mental capabilities or lack of experience and knowledge if they have been given supervision or instruction concerning use of the appliance in a safe way and understand the hazards involved.
- Children shall not play with the appliance. Cleaning and user maintenance shall not be made by children without supervision.
- Installation and repair procedures must always be performed by Authorized Service Agents. The manufacturer shall not be held responsible for damages arising from procedures carried out by unauthorized

persons which may also void the warranty. Before installation, read the instructions carefully.

- Do not operate the product if it is defective or has any visible damage.
- Ensure that the product function knobs are switched off after every use.

Electrical safety

- If the product has a failure, it should not be operated unless it is repaired by an Authorized Service Agent. There is the risk of electric shock!
- Only connect the product to a grounded outlet/line with the voltage and protection as specified in the "Technical specifications". Have the grounding installation made by a qualified electrician while using the product with or without a transformer. Our company shall not be liable for any problems arising due to the product not being earthed in accordance with the local regulations.
- Never wash the product by spreading or pouring water

onto it! There is the risk of electric shock!

- The product must be disconnected during installation, maintenance, cleaning and repairing procedures.
- If the power connection cable for the product is damaged, it must be replaced by the manufacturer, its service agent or similarly qualified persons in order to avoid a hazard.
- Only use the connection cable specified in the "Technical specifications".
- The appliance must be installed so that it can be completely disconnected from the mains supply. The separation must be provided by a switch built into the fixed electrical installation, according to construction regulations.
- Rear surface of the oven gets hot when it is in use. Make sure that the electrical connection does not contact the rear surface; otherwise, connections can get damaged.
- Do not trap the mains cable between the oven door and frame and do not route it over

hot surfaces. Otherwise, cable insulation may melt and cause fire as a result of short circuit.

- Any work on electrical equipment and systems should only be carried out by authorized and qualified persons.
- In case of any damage, switch off the product and disconnect it from the mains. To do this, turn off the fuse at home.
- Make sure that fuse rating is compatible with the product.

Product safety

- The appliance and its accessible parts become hot during use. Care should be taken to avoid touching heating elements. Children less than 8 years of age shall be kept away unless continuously supervised.
- Never use the product when your judgment or coordination is impaired by the use of alcohol and/or drugs.
- Be careful when using alcoholic drinks in your dishes. Alcohol evaporates at high temperatures and may cause fire since it can ignite when it comes into contact with hot surfaces.

- Do not place any flammable materials close to the product as the sides may become hot during use.
- During use the appliance becomes hot. Care should be taken to avoid touching heating elements inside the oven.
- Keep all ventilation slots clear of obstructions.
- Do not heat closed tins and glass jars in the oven. The pressure that would build-up in the tin/jar may cause it to burst.
- Do not place baking trays, dishes or aluminium foil directly onto the bottom of the oven. The heat accumulation might damage the bottom of the oven.
- Do not use harsh abrasive cleaners or sharp metal scrapers to clean the oven door glass since they can scratch the surface, which may result in shattering of the glass.
- Do not use steam cleaners to clean the appliance as this may cause an electric shock.
- Placing the wire shelf and tray onto the wire racks properly
- It is important to place the wire shelf and/or tray onto the rack

properly. Slide the wire shelf or tray between 2 rails and make sure that it is balanced before placing food on it (Please see the following figure).

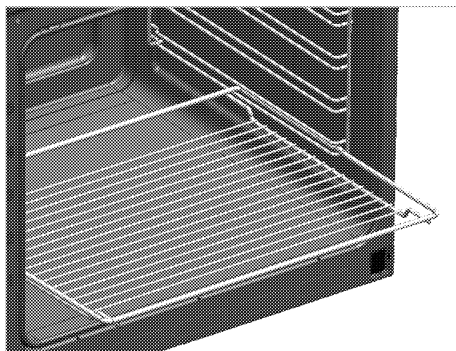

- Do not use the product if the front door glass removed or cracked.
- Do not use the oven handle to hang towels for drying. Do not hang up towel, gloves, or similar textile products when the grill function is at open door.
- Always use heat resistant oven gloves when putting in or removing dishes into/from the hot oven.
- Ensure that the appliance is switched off before replacing the lamp to avoid the possibility of electric shock.

Prevention against possible fire risk!

- Ensure all electrical connections are secure and tight to prevent risk of arcing.
- Do not use damaged cables or extension cables.
- Ensure liquid or moisture is not accessible to the electrical connection point.

Intended use

- This product is designed for domestic use. Commercial use will void the guarantee.
- This appliance is for cooking purposes only. It must not be used for other purposes, for example room heating.
- This product should not be used for warming the plates under the grill, drying towels, dish cloths etc. by hanging them on the oven door handles. This product should also not be used for room heating purposes.
- The manufacturer shall not be liable for any damage caused by improper use or handling errors.
- The oven can be used for defrosting, baking, roasting and grilling food.

Safety for children

- Accessible parts may become hot during use. Young children should be kept away.
- The packaging materials will be dangerous for children. Keep the packaging materials away from children. Please dispose of all parts of the packaging according to environmental standards.
- Electrical products are dangerous to children. Keep children away from the product when it is operating and do not allow them to play with the product.
- Do not place any items above the appliance that children may reach for.
- When the door is open, do not load any heavy object on it and do not allow children to sit on it. It may overturn or door hinges may get damaged.

Disposing of the old product

Compliance with the WEEE Directive and Disposing of the Waste Product:



This product complies with EU WEEE Directive (2012/19/EU). This product bears a classification symbol for waste electrical and electronic equipment (WEEE).

This product has been manufactured with high quality parts and materials which can be reused and are suitable for recycling. Do not dispose of the waste product with normal domestic and other wastes at the end of its service life. Take it to the collection center for the recycling of electrical and electronic equipment. Please consult your local authorities to learn about these collection centers.

Compliance with RoHS Directive:

The product you have purchased complies with EU RoHS Directive (2011/65/EU). It does not contain harmful and prohibited materials specified in the Directive.

Package information

- Packaging materials of the product are manufactured from recyclable materials in accordance with our National Environment Regulations. Do not dispose of the packaging materials together with the domestic or other wastes. Take them to the packaging material collection points designated by the local authorities.

2 General information

Overview

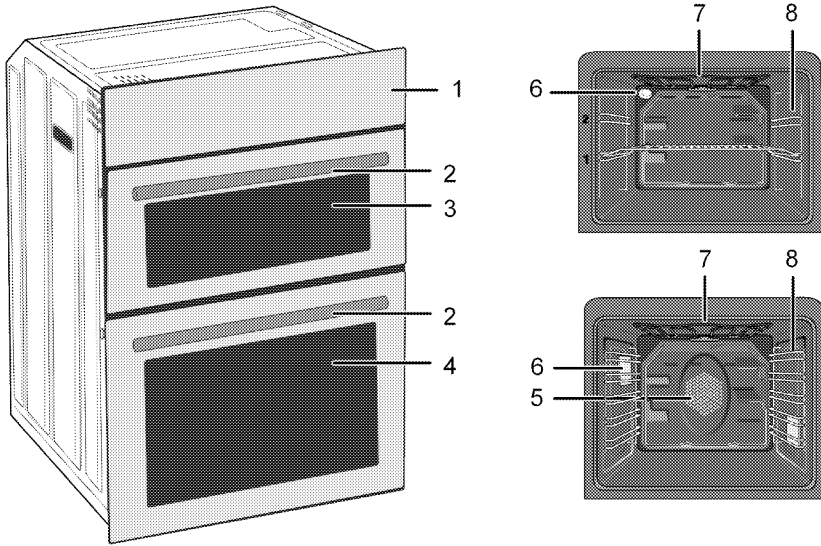

- | | | | |
|---|---------------|---|--------------------------------|
| 1 | Control panel | 5 | Fan motor (behind steel plate) |
| 2 | Handle | 6 | Lamp |
| 3 | Top oven | 7 | Grill heating element |
| 4 | Main oven | 8 | Shelf positions |

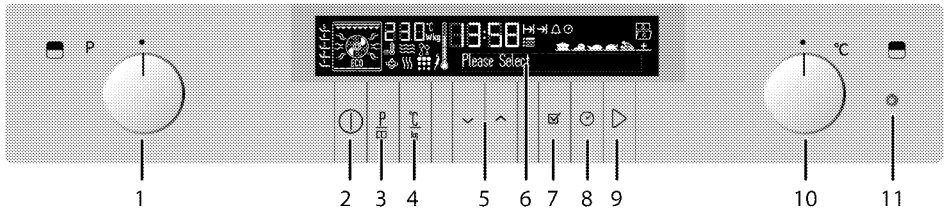

- | | | | |
|---|--|----|------------------------------|
| 1 | Top oven function knob | 7 | OK key |
| 2 | ON/OFF key | 8 | Time and settings key |
| 3 | Program selection key | 9 | Start/stop cooking key |
| 4 | Temperature/weight/booster setting key | 10 | Top oven thermostat knob |
| 5 | Up/down keys (Menu step) | 11 | Thermostat lamp for top oven |
| 6 | Display | | |

Package contents



Accessories supplied can vary depending on the product model. Not every accessory described in the user manual may exist on your product.

1. User manual

2. Oven tray

- Used for pastries, frozen foods and big roasts.

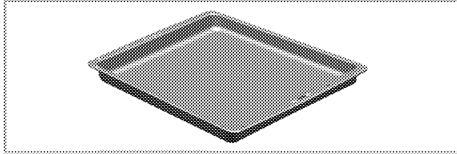

3. Wire Shelf

- Used for roasting and for placing the food to be baked, roasted or cooked in casserole dishes to the desired rack.

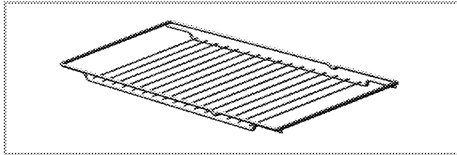

4. Small wire shelf

- It is placed into the tray (if supplied) in order to collect the dripping fat while grilling so that the oven is kept clean.

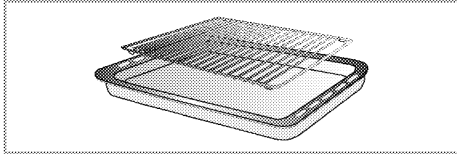

5. Placing the wire shelf and tray onto the telescopic racks properly

- Telescopic racks allow you to install and remove the trays and wire shelf easily.
- When using the tray and wire shelf with telescopic racks, make sure that the pins at the rear section of the telescopic rack stands against the edges of the wire shelf and tray.

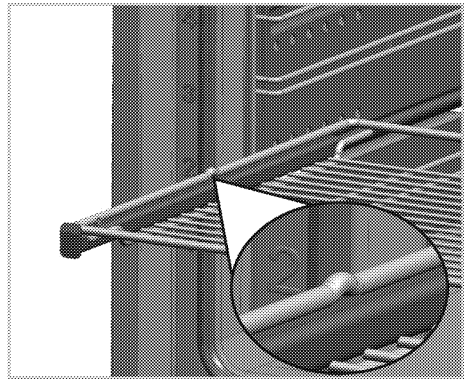
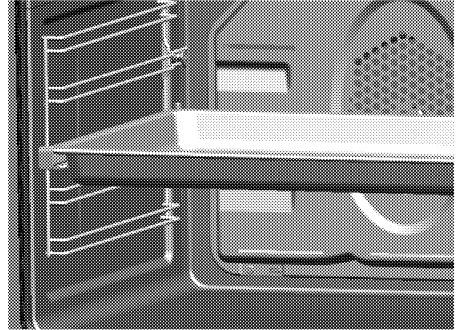

Technical specifications

GENERAL	
Voltage / frequency	220-240 V ~ 50 Hz
Total power consumption	5.5 kW
Fuse	min. 25 A
Cable type / section	H05VV-FG 3 x 2,5 mm ² or equivalent
OVEN/GRILL	
External dimensions (height / width / depth)	890 mm/594 mm/567 mm
Installation dimensions (height / width / depth)	880 mm/560 mm/min. 550 mm
Main oven	Multifunction oven
Inner lamp	15/25 W
Grill power consumption	2.2 kW
Top oven	Conventional oven / Grill
Inner lamp	15/25 W
Grill power consumption	2.2 kW

Basics: Information on the energy label of electrical ovens is given in accordance with the EN 60350-1 / IEC 60350-1 standard. Those values are determined under standard load with bottom-top heater or fan assisted heating (if any) functions.

Energy efficiency class is determined in accordance with the following prioritization depending on whether the relevant functions exist on the product or not. 1-Cooking with eco-fan, 2- Turbo slow cooking, 3- Turbo cooking, 4- Fan assisted bottom/top heating, 5-Top and bottom heating.

** See. *Installation*, page 12.



Technical specifications may be changed without prior notice to improve the quality of the product.



Figures in this manual are schematic and may not exactly match your product.



Values stated on the product labels or in the documentation accompanying it are obtained in laboratory conditions in accordance with relevant standards. Depending on operational and environmental conditions of the product, these values may vary.

3 Installation

Product must be installed by a qualified person in accordance with the regulations in force. The manufacturer shall not be held responsible for damages arising from procedures carried out by unauthorized persons which may also void the warranty.



Preparation of location and electrical installation for the product is under customer's responsibility.



DANGER:

The product must be installed in accordance with all local electrical regulations.



DANGER:

Prior to installation, visually check if the product has any defects on it. If so, do not have it installed.
Damaged products cause risks for your safety.

Before installation

The appliance is intended for installation in commercially available kitchen cabinets. A safety distance must be left between the appliance and the kitchen walls and furniture. See figure (values in mm).

- * Surfaces, synthetic laminates and adhesives used must be heat resistant (100 °C minimum).
- * Kitchen cabinets must be set level and fixed.
- * If there is a drawer beneath the oven, a shelf must be installed between oven and drawer.
- * Carry the appliance with at least two persons.
- * The following installation drawings are representational and may not match exactly with your appliance.



Do not install the appliance next to refrigerators or freezers. The heat emitted by the appliance will lead to an increased energy consumption of cooling appliances.



The door and/or handle must not be used for lifting or moving the appliance.



If the appliance has wire handles, push the handles back into the side walls after moving the appliance.

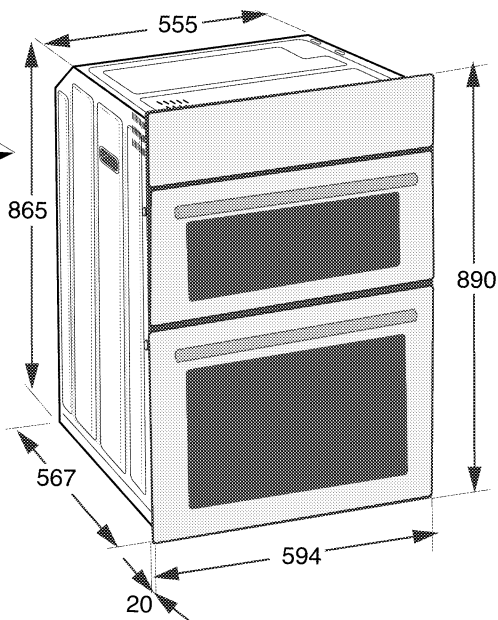
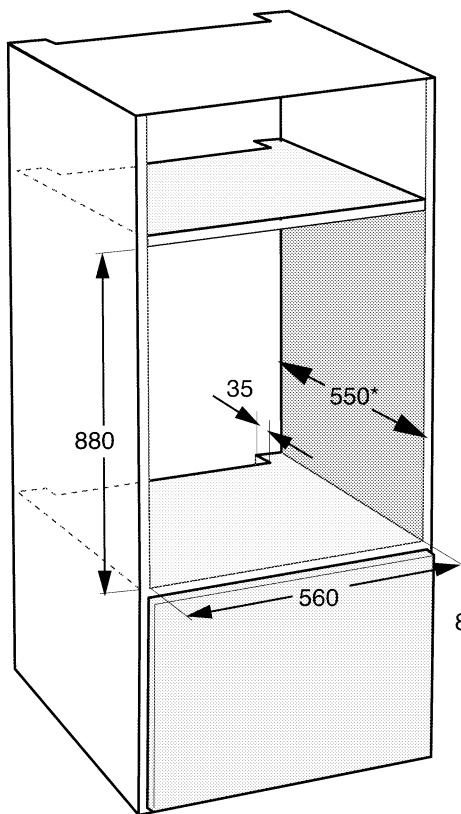

* min.

Installation and connection

- * The product must be installed in accordance with all local gas and electrical regulations.

Electrical connection

Connect the product to a grounded outlet/line protected by a fuse of suitable capacity as stated in the "Technical

specifications" table. Have the grounding installation made by a qualified electrician while using the product with or without a transformer. Our company shall not be liable for any damages that will arise due to using the product without a grounding installation in accordance with the local regulations.

**DANGER:**

The product must be connected to the mains supply only by an authorised and qualified person. The product's warranty period starts only after correct installation.

Manufacturer shall not be held responsible for damages arising from procedures carried out by unauthorised persons.

**DANGER:**

The power cable must not be clamped, bent or trapped or come into contact with hot parts of the product.

A damaged power cable must be replaced by a qualified electrician. Otherwise, there is risk of electric shock, short circuit or fire!

- * Connection must comply with national regulations.
- * The mains supply data must correspond to the data specified on the type label of the product. Open the front door to see the type label.
- * Power cable of your product must comply with the values in "Technical specifications" table.

**DANGER:**

Before starting any work on the electrical installation, disconnect the product from the mains supply. There is the risk of electric shock!

Connecting the power cable

1. **If a power cable is not supplied together with your product**, a power cable that you would select from the table in accordance with the electrical installation at your home must be connected to your product by following the instructions in cable diagram.

This product must only be connected by a qualified electrician such as a technician from the local electricity company or NICEIC

registered contractor to a suitable double-pole control unit with a minimum contact clearance of 3 mm in all poles. This control unit must be installed accordance with the IEE regulation. Failure to obey this instruction may cause operational problems and invalidate the product warranty.



Additional protection by a residual current circuit breaker is recommended.

2. Open the terminal block cover with a screwdriver.
3. Insert the power cable through the cable clamp below the terminal and secure it to the main body with the integrated screw on cable clamping component.
4. Connect the cables according to the supplied diagram.

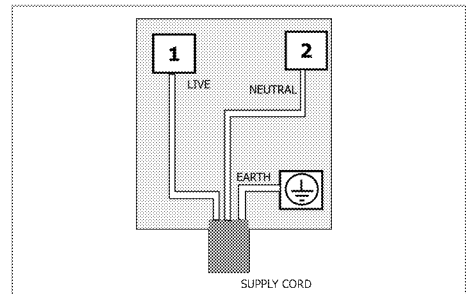

5. After completing the wire connections, close the terminal block cover.
6. Route the power cable so that it will not contact the product and get squeezed between the product and the wall.



Power cable must not be longer than 2 m because of safety reasons.

Installing the product

1. Slide the oven into the cabinet, align and secure it while making sure that the power cable is not broken and/or trapped.

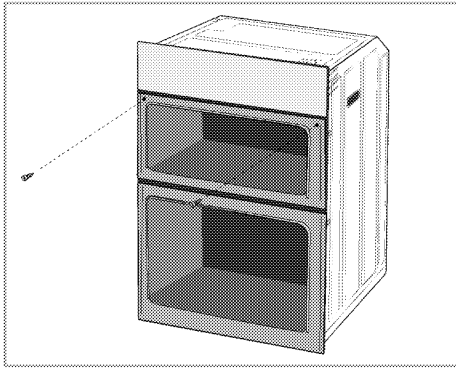

Secure the oven with 2 screws as illustrated.

For products with cooling fan

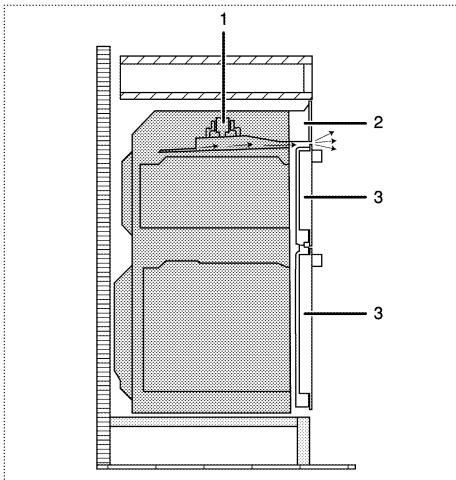

- 1 Cooling fan
- 2 Control panel
- 3 Door

The built-in cooling fan cools both the built-in cabinet and the front of the product.



Cooling fan continues to operate for about 20-30 minutes after the oven is switched off.

If you have cooked by programming the timer of the oven, cooling fan will also be switched off at the end of the cooking time together with all functions.

Final check

1. Plug in the power cable and switch on the product's fuse.
2. Check the functions.

Future Transportation

- * Keep the product's original carton and transport the product in it. Follow the instructions on the carton. If you do not have the original carton, pack the product in bubble wrap or thick cardboard and tape it securely.
- * To prevent the wire grill and tray inside the oven from damaging the oven door, place a strip of cardboard onto the inside of the oven door that lines up with the position of the trays. Tape the oven door to the side walls.
- * Do not use the door or handle to lift or move the product.



Do not place any objects onto the product and move it in upright position.



Check the general appearance of your product for any damages that might have occurred during transportation.

4 Preparation

Tips for saving energy

The following information will help you to use your appliance in an ecological way, and to save energy:

- Use dark coloured or enamel coated cookware in the oven since the heat transmission will be better.
- While cooking your dishes, perform a preheating operation if it is advised in the user manual or cooking instructions.
- Do not open the door of the oven frequently during cooking.
- Try to cook more than one dish in the oven at the same time whenever

possible. You can cook by placing two cooking vessels onto the wire shelf.

- Cook more than one dish one after another. The oven will already be hot.
- You can save energy by switching off your oven a few minutes before the end of the cooking time. Do not open the oven door.
- Defrost frozen dishes before cooking them.

Initial use

Day time



Before you can use the oven, the time must be set. If the time is not set, oven will not operate.

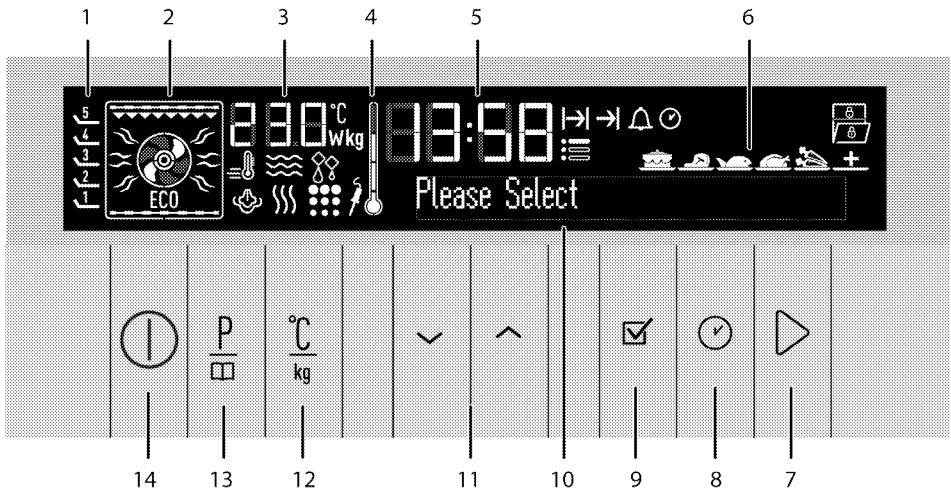



- 1 Shelf positions
- 2 Function display
- 3 Temperature/weight indicator field
- 4 Oven Inner Temperature symbol
- 5 Current time indicator field
- 6 Convenience food selection display
- 7 Start/stop cooking key
- 8 Time and settings key
- 9 OK key
- 10 Text display
- 11 Up/down keys (Menu step)
- 12 Temperature/weight/booster setting key
- 13 Program selection key
- 14 ON/OFF key

Language setting



Language can only be set when the oven is switched off.

1. Connect the power cable and switch on the product's fuse.

- When you switch on the oven for the first time, "Language: English" appears on the Text display
- Touch  keys to select the desired language.
- Touch  to confirm the setting.
» It returns to the stand-by display.

Set the time



- After selecting the language, "Time setting" appears on the Text display and  symbol flashes. Set the time with  keys.
- Touch  to confirm the time.
» It returns to the stand-by display. Only the current time appears on the display.

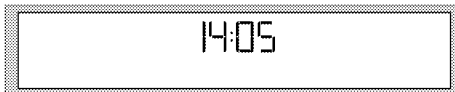

 In case of power outage or when the product is disconnected and reconnected again, time setting menu is displayed. However, the set time is preserved in power outages shorter than 20 minutes. In such cases, you can continue by confirming the time value.

First cleaning of the appliance

 The surface might get damaged by some detergents or cleaning materials. Do not use aggressive detergents, cleaning powders/creams or any sharp objects during cleaning. Do not use harsh abrasive cleaners or sharp metal scrapers to clean the oven door glass since they can scratch the surface, which may result in shattering of the glass.

- Remove all packaging materials.

- Wipe the surfaces of the appliance with a damp cloth or sponge and dry with a cloth.

Initial heating

Heat up the product for about 30 minutes and then switch it off. Thus, any production residues or layers will be burnt off and removed.

 **WARNING**
Hot surfaces cause burns!
Product may be hot when it is in use. Never touch the hot burners, inner sections of the oven, heaters and etc. Keep children away. Always use heat resistant oven gloves when putting in or removing dishes into/from the hot oven.

Electric oven

- Take all baking trays and the wire grill out of the oven.
- Close the oven door.
- Select Static position.
 - Select the highest oven power; See *How to operate the electric oven*, page 18.
 - Operate the oven for about 30 minutes.
 - Turn off your oven; See *How to operate the electric oven*, page 18

Grill oven

- Take all baking trays and the wire grill out of the oven.
- Close the oven door.
- Select the highest grill power; see *How to operate the grill*, page 31.
- Operate the grill about 30 minutes.
- Turn off your grill; see *How to operate the grill*, page 31

 Smoke and smell may emit for a couple of hours during the initial operation. This is quite normal. Ensure that the room is well ventilated to remove the smoke and smell. Avoid directly inhaling the smoke and the smell that emits.

5 How to operate the oven

General information on baking, roasting and grilling



WARNING

Hot surfaces cause burns!
Product may be hot when it is in use.
Never touch the hot burners, inner sections of the oven, heaters and etc.
Keep children away.
Always use heat resistant oven gloves when putting in or removing dishes into/from the hot oven.



DANGER:

Be careful when opening the oven door as steam may escape.
Exiting steam can scald your hands, face and/or eyes.

Tips for baking

- Use non-sticky coated appropriate metal plates or aluminum vessels or heat-resistant silicone moulds.
- Make best use of the space on the rack.
- Place the baking mould in the middle of the shelf.
- Select the correct rack position before turning the oven or grill on. Do not change the rack position when the oven is hot.
- Keep the oven door closed.

Tips for roasting

- Treating whole chicken, turkey and large piece of meat with dressings such as lemon juice and black pepper before cooking will increase the cooking performance.
- It takes about 15 to 30 minutes longer to roast meat with bones when compared to roasting the same size of meat without bones.
- Each centimeter of meat thickness requires approximately 4 to 5 minutes of cooking time.

- Let meat rest in the oven for about 10 minutes after the cooking time is over. The juice is better distributed all over the roast and does not run out when the meat is cut.
- Fish should be placed on the middle or lower rack in a heat-resistant plate.

Tips for grilling

When meat, fish and poultry are grilled, they quickly get brown, have a nice crust and do not get dry. Flat pieces, meat skewers and sausages are particularly suited for grilling as are vegetables with high water content such as tomatoes and onions.

- Distribute the pieces to be grilled on the wire shelf or in the baking tray with wire shelf in such a way that the space covered does not exceed the size of the heater.
- Slide the wire shelf or baking tray with grill into the desired level in the oven. If you are grilling on the wire shelf, slide the baking tray to the lower rack to collect fats. Add some water in the tray for easy cleaning.



Foods that are not suitable for grilling carry the risk of fire. Only grill food which is suitable for intensive grilling heat.
Do not place the food too far in the back of the grill. This is the hottest area and fatty food may catch fire.

How to operate the electric oven



Before you can use the oven, the time must be set. If the time is not set, oven will not operate.

Your oven is equipped with pop-out knob that protrude when you press them.

1. Press inwards to protrude the knob and then turn it to make the desired setting.

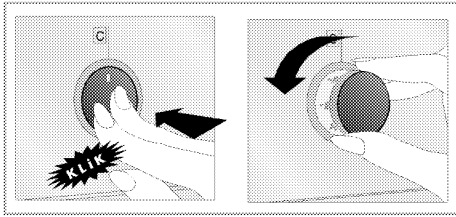

- When the cooking process is finished, turn the knob to off (upper) position and press it inwards.

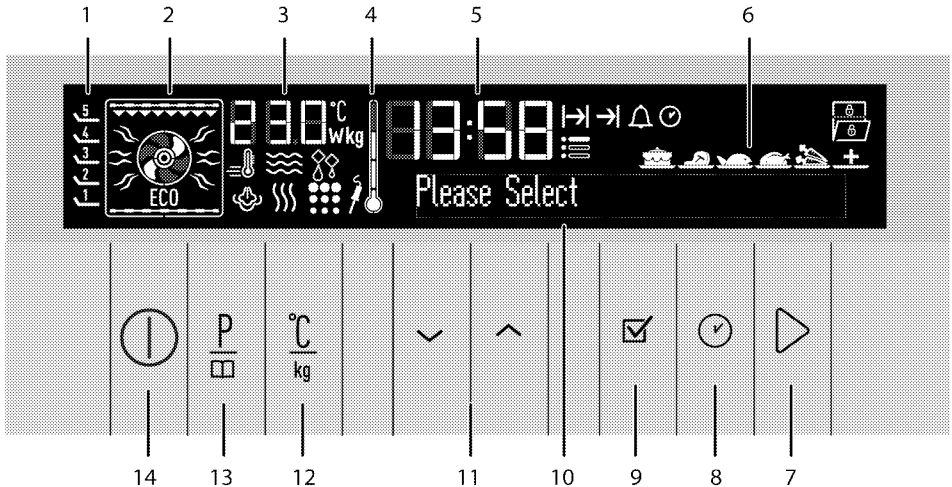

- Shelf positions
- Function display
- Temperature/weight indicator field
- Oven Inner Temperature symbol
- Current time indicator field
- Convenience food selection display
- Start/stop cooking key
- Time and settings key
- OK key
- Text display
- Up/down keys (Menu step)
- Temperature/weight/booster setting key
- Program selection key
- ON/OFF key

- Meat probe symbol *
- Pyro symbol *
- Steam symbol *
- * Varies depending on the product model.

Oven returns to stand-by display after it is switched on and the current time is set. Only the current time appears on the display. Only the and keys are functional when the display is in this status. You can perform all actions in the Settings menu. See *Settings menu*, page 30.

Display symbols:

- Rapid heating (Booster) symbol
- Cooking time symbol
- End of cooking time symbol
- Alarm symbol
- Current time symbol
- Settings symbol
- Defrost symbol
- Keylock symbol
- Door open symbol

If you touch key briefly in this screen, "Keep pressed for 1 second" warning appears in the text field. Touch the key for longer than 1 second to switch on the oven.



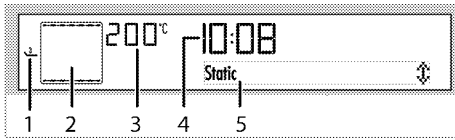

Select temperature and operating mode

1. Touch  key to switch on the oven.
2. Initial operation screen appears when the oven is turned on.



- 1 Shelf positions
- 2 Function display
- 3 Temperature/weight indicator field
- 4 Current time indicator field
- 5 Text display



This screen contains the recommended temperature under temperature/weight indicator and the active heaters and recommended tray position in the function display.

3. Touch  or  keys to select the desired operating mode (function).

After the function is selected, "Temperature", "Cook time", "Cook end time" and "Booster" (rapid heating) can be set.

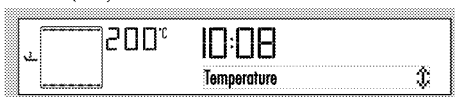

4. If you want to change the temperature, touch  once to reach the temperature display.



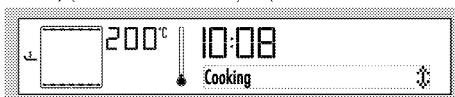

5. Touch / until the desired temperature appears in the Temperature/Weight Indicator field. Touch  to set the temperature when the desired value appears on the display.

6. If cooking function and temperature values are suitable, touch  key to start cooking. Cooking starts and "Cooking" appears on the display.



 If the oven door is opened during cooking, "Door open" warning and  symbol appears on the display.

 If you touch  key briefly in this screen, "Keep pressed for 1 second" warning appears in the text field.

Touch the  key for longer than 1 second to start cooking.

Switching off the electric oven

Touch  key to switch off the oven.

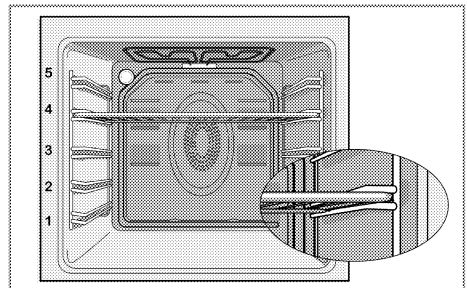

Rack positions (For models with wire grill)

It is important to place the wire grill onto the wire rack correctly. Wire grill must be inserted between the wire racks as illustrated in the figure.





Do not let the wire grill stand against the rear wall of the oven. Slide your wire grill to the front section of the rack and settle it with the help of the door in order to obtain a good grill performance.

Function table

Function table indicates the functions that can be used in the oven and their respective maximum and minimum temperatures.

 Functions vary depending on the product model.

 Due to safety reasons, maximum time that can be set for "Cook time" is limited with 6 hours at all positions apart from "Warm Keeping" and "Low Temp. Cooking" functions.

-  While making any adjustment, related symbols will flash on the display.
-  Program will be cancelled in case of power failure. You must reprogram the oven.
-  Current time cannot be set while the oven is operating in any function, or if semi-automatic or full automatic programming is made on the oven.
-  Even if the oven is switched off, oven lamp lights up when the oven door is opened.

Static



Static+fan

Hot air heated by the bottom and top heaters is evenly distributed throughout the oven rapidly by means of the fan. Cook with one tray.



Fan heating

Warm air heated by the rear heater is evenly distributed throughout the oven rapidly by means of the fan. It is suitable for cooking your meals in different rack levels and preheating is not required in most cases. Suitable for cooking with multi trays.



 When the oven door is opened, the fan motor will not run in order to keep the hot air inside.

Function	Recommended temperature (°C)	Temperature range (°C)
Static	200	40-280
Static + fan	175	40-280
Fan heating	180	40-280
Multi (3D)	205	40-280
Fan heat.+bottom	210	40-280
Full grill+Fan	200	40-280
Full grill	280	40-280
Low grill	280	40-280
Eco fan	180	160-220
Bottom heating	180	40-220
Warm keeping	60	40-100
Low temp. cooking	100	50-150
Defrost	-	-

* Functions vary depending on the product model.

Operating modes

All functions in your oven (including the main oven) are described in this section.

The order of operating modes shown here may be different from the arrangement on your product.

Static

Food is heated simultaneously from the top and bottom. It is suitable for cakes, pastries, or cakes and casseroles in baking moulds. Cook with one tray.

Multi (3-D) cooking

Top heating, bottom heating and fan assisted heating are in operation. Food is cooked evenly and quickly all around. Cook with one tray.



Fan heat.+bottom

Bottom heating and fan assisted heating (in the rear wall) are in operation. Suitable for baking pizza.



Full grill+Fan

Hot air heated by the full grill is distributed very fast in the oven by means of the fan. It is suitable for grilling large amount of meat.



- Put big or medium-sized portions in correct rack position under the grill heater for grilling.
- Set the temperature to maximum level.
- Turn the food after half of the grilling time.

Full grill

Large grill at the ceiling of the oven is in operation. It is suitable for grilling large amount of meat.



- Put big or medium-sized portions in correct rack position under the grill heater for grilling.
- Set the temperature to maximum level.
- Turn the food after half of the grilling time.

Low Grill

Small grill at the ceiling of the oven is in operation. Suitable for grilling and gratin dishes.



- Put small or medium-sized portions in correct rack position under the grill heater for grilling.
- Set the temperature to maximum level.
- Turn the food after half of the grilling time.

Slow cooking/Eco Fan Heating

To save power, you can use this function instead of the cooking operations that you would perform by using Fan Heating at 160-220 °C temperature range. However, the cooking time will increase a little bit.

Cooking times related to this function are indicated in "Slow cooking/Eco Fan Heating" table.



Bottom Heating

Only bottom heating is in operation. It is suitable for pizza and for subsequent browning of food from the bottom.



Warm keeping

Used for keeping food at a temperature ready for serving for a long period of time.

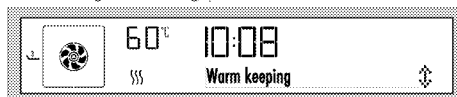

Low temperature cooking

Used for cooking at low temperatures in longer times (10-15 hours).

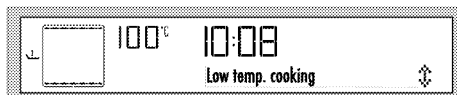

Defrost

Suitable for thawing frozen granular food slowly at room temperature and cooling down the cooked food.



How to operate the oven control unit

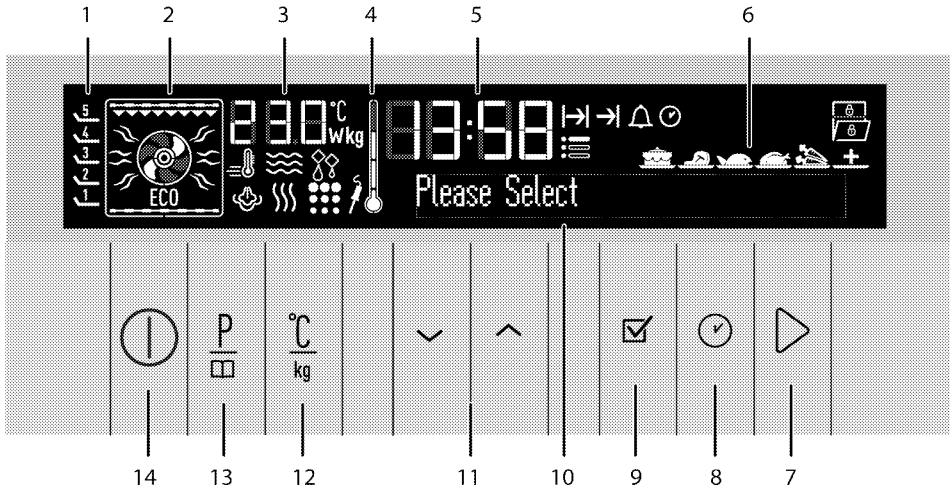

- Shelf positions
- Function display
- Temperature/weight indicator field
- Oven Inner Temperature symbol
- Current time indicator field
- Convenience food selection display
- Start/stop cooking key
- Time and settings key
- OK key
- Text display
- Up/down keys (Menu step)
- Temperature/weight/booster setting key
- Program selection key
- ON/OFF key
- Touch \wedge or \vee keys to select the desired operating mode (function).
- If you want to change the temperature, touch $\frac{^{\circ}\text{C}}{\text{kg}}$ once to reach the temperature display.
- Touch \wedge/\vee until the desired temperature appears in the Temperature/Weight Indicator field. Touch \checkmark to set the temperature when the desired value appears on the display.
- For cooking time, press ⌚ key for once to scroll to the "Cook time" on the text display. ⏪ symbol flashes at the same time.
- Touch \wedge/\vee keys to set the desired cooking time and confirm the setting by touching the \checkmark key. Once the Cook Time is set, ⏪ will be displayed continuously.

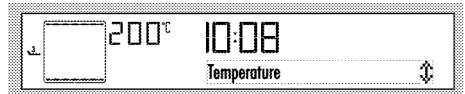

Enable semi-automatic operation



In this operation mode, you may adjust the time period during which the oven will operate (cook time).

- Touch ⏻ key to switch on the oven.

i If you touch ⏻ key briefly in this screen, "Keep pressed for 1 second" warning appears in the text field. Touch the ⏻ key for longer than 1 second to switch on the oven.







- Put your dish into the oven and close the door.
- If cooking function, temperature and time values are suitable, touch  key to start cooking. Cooking starts and **"Cooking"** appears on the display.

 If you touch  key briefly in this screen, "Keep pressed for 1 second" warning appears in the text field.

Touch the  key for longer than 1 second to start cooking.





» The oven will be heated up to the preset temperature and will maintain this temperature until the end of the cooking time you selected. The oven lamp is lit during the cooking process.

 All segments of the inner oven temperature symbol (4) will turn on when the oven reaches the set temperature.







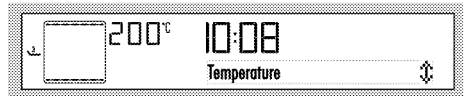

- After the cooking is completed, **"Good appetite... Press  to continue"** appears on the display and alarm signal is heard.
- To stop the alarm signal, just touch any key. Oven will continue operating at the selected mode if you touch  key. Alarm stops.
- Oven is switched off automatically and the current time is displayed if you do not touch the  key.

Switch on fully automatic operation



In this operation mode you can adjust cooking time and end of cooking time.

- Touch  key to switch on the oven.
- Touch  or  keys to select the desired operating mode (function).
- If you want to change the temperature, touch  once to reach the temperature display.







- Touch / until the desired temperature appears in the Temperature/Weight Indicator field. Touch  to set the temperature when the desired value appears on the display.
- For cooking time, press  key for once to scroll to the "Cook time" on the text display.  symbol flashes at the same time.
- Touch / keys to set the desired cooking time and confirm the setting by touching the  key. Once the Cook Time is set,  will be displayed continuously.

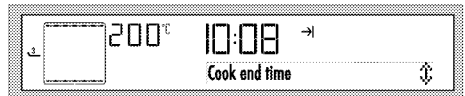



- For the end of cooking time, touch  with short intervals until **"Cook end time"** appears on the text display.  flashes at the same time.



- Touch / keys to set the desired end of cooking time and confirm the setting by touching the  key. Once the Cook end time is set,  will be displayed continuously.
 - Put your dish into the oven and close the door.
 - If cooking function, temperature, time and end of cooking time values are suitable, touch  key to start cooking. **"Waiting"** appears on the display.
- » Oven timer automatically calculates the startup time for cooking by deducting the cooking time from the end of cooking time you have set.

- Selected operation mode is activated when the startup time of cooking has come, "**Cooking**" appears on the display and the oven is heated up to the set temperature. It maintains this temperature until the end of the cooking time. The oven lamp is lit during the cooking process.

i All segments of the inner oven temperature symbol (4) will turn on when the oven reaches the set temperature.

- After the cooking is completed, "**Good appetite... Press  to continue**" appears on the display and alarm signal is heard.
- To stop the alarm signal, just touch any key. Oven will continue operating at the selected mode if you touch  key. Alarm stops.
- Oven is switched off automatically and the current time is displayed if you do not touch the  key.

i If you want to cancel the semi-automatic or automatic programming after you have set them, you need to reset the cooking time. You can also switch off the oven by touching the  key if you want.

Setting the booster (Quick heating)



Use Booster (rapid pre-heating) function to make the oven reach the desired temperature faster.

i Booster can not be selected in Defrost, Slow cooking, Warm keeping and Low temperature cooking functions. Booster settings will be cancelled in case of power outage.

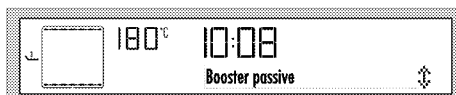

Select the desired cooking function and then:





- Touch the  key twice. "Booster passive" appears on the display.



- Touch the  key for once. "Booster active" warning and  symbol appear on the display. Touch  to confirm the setting.



- If cooking function and temperature values are suitable, touch  key to start cooking. Cooking starts and "**Cooking**" appears on the display.
»  symbol disappears as soon as the oven reaches the desired temperature and oven resumes operating in the function it was in before the Booster function.

- To cancel Booster function, touch the  key with short intervals until "**Booster active**" appears on the display.
- Touch the  key for once. "Booster passive" warning appears and  symbol disappears on the display. Touch  to confirm the setting.

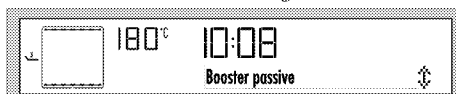





Using the keylock

You can prevent oven from being intervened with by activating the Keylock function.



i Keylock can be used either when the oven is operating or not. Oven can be switched off by touching the  key even when the keylock is activated while the oven is operating.

Activating the keylock

- Touch  key with short intervals until "**Keylock passive**" appears on the display.  symbol flashes on the display.

2. Touch  key for once to activate the keylock. After activating the keylock, "Key lock active" will appear on the display. Then, the  symbol will appear.
3. Touch  to confirm the setting.



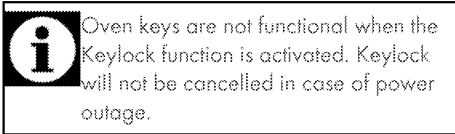

» After activating the keylock, "Keylock active" warning and  symbol will appear on the display when you press any key (except /  keys).



Oven keys are not functional when the Keylock function is activated. Keylock will not be cancelled in case of power outage.

Deactivating the keylock

1. Touch  key twice to deactivate the keylock. "Key lock passive" appears on the display.
2. Touch  to confirm the setting.



» Key lock is deactivated and the  symbol on the display disappears.

Using the clock as an alarm

You can use the clock of the product for any warning or reminder apart from the cooking programme.



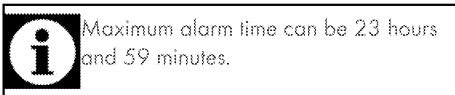



The alarm clock has no influence on the functions of the oven. It is only used as a warning. For example, this is useful when you want to turn food in the oven at a certain point of time. Alarm clock will give a signal once the time you set is over.







Maximum alarm time can be 23 hours and 59 minutes.

To set the alarm:



1. Touch  key with short intervals until  symbol appears on the display.
2. Touch /  keys to set the desired time and confirm the setting by touching the  key.  symbol remains lit after setting the alarm time.
3. After the alarm time is finished,  will start flashing and an alarm signal is heard.
4. Press any key to stop the alarm.

To cancel the alarm:

1. Touch  key with short intervals until  symbol appears on the display.
 2. Touch the  key until "00:00" appears on the display and confirm the setting by touching the  key.
- » Alarm is cancelled and  symbol disappears.

Cooking times table

i The timings in this chart are meant as a guide. Timings may vary due to temperature of food, thickness, type and your own preference of cooking.

Baking and roasting

i 1st rack of the oven is the **bottom** rack.

Dish	Cooking level number		Rack position	Temperature (°C)	Cooking time (approx. in min.)
Cakes in tray*	One level		3	175	25 ... 30
Cakes in mould*	One level		2	180	40 ... 30
Cakes in cooking paper*	One level		3	175	25 ... 30
	2 levels		1-5	175	30 ... 40
	3 levels		1-3-5	180	45 ... 55
Sponge cake*	One level		3	200	5 ... 10
	2 levels		1-5	175	20 ... 30
Cookies*	One level		3	175	25 ... 30
	2 levels		1-5	170 ... 190	30 ... 40
	3 levels		1-3-5	175	35 ... 45
Dough pastry*	One level		2	200	30 ... 40
	2 levels		1-5	200	45 ... 55
	3 levels		1-3-5	200	55 ... 65
Rich pastry*	One level		2	200	25 ... 35
	2 levels		1-5	200	35 ... 45
	3 levels		1-3-5	190	45 ... 55
Leaven*	One level		2	200	35 ... 45
	2 levels		1-3	190	35 ... 45
Lasagna*	One level		2-3	200	30 ... 40
Pizza*	One level		2	200 ... 220	15 ... 20
	One level		3	200	10 ... 15
Beef steak (whole) / Roast	One level		3	25 min. 250/max, then 180 ... 190	100 ... 120
Leg of Lamb (casserole)	One level		3	25 min. 250/max, then 190	70 ... 90
	One level		3	25 min. 250/max, then 190	60 ... 80
Roasted chicken	One level		2	15 min. 250/max, then 180 ... 190	55 ... 65
	One level		2	15 min. 250/max, then 180 ... 190	55 ... 65
Turkey (5,5 kg)	One level		1	25 min. 250/max, then 180 ... 190	150 ... 210
	One level		1	25 min. 250/max, then 180 ... 190	150 ... 210
Fish	One level		3	200	20 ... 30
	One level		3	200	20 ... 30

When cooking with 2 trays at the same time, place the deeper tray on the upper rack and the other one on the lower rack.
* It is suggested to perform preheating for all foods.

Slow cooking/Eco Fan Heating



Do not change the cooking temperature after cooking starts in Slow cooking/Eco Fan Heating mode.



Do not open the door during cooking in the Slow cooking/Eco Fan Heating mode.

Dish	Cooking level number		Rack position	Temperature (°C)	Cooking time (approx. in min.)
Meat-Casserole	One level		3	160	100 ... 120
Chicken-Casserole	One level		3	160	70 ... 100
Haricot Bean	One level		3	160	130 ... 150
Eggplant-Casserole	One level		3	160	130 ... 150
Steak - Whole	One level		3	160	110 ... 130
Steak - Sliced	One level		3	160	100 ... 120
Cakes in cooking paper	One level		3	185	35 ... 40
Cookies	One level		3	185	30 ... 35
Dough pastry	One level		3	200	40 ... 45
Rich pastry	One level		3	200	40 ... 45

- Perform a preheating for 6-7 minutes.
- White/red meats have to be flipped over in the pan prior to cooking until boiled down.
- Haricot beans have to be boiled for 30 minutes prior to cooking. You may directly use canned bean.
- Covering the cooking pan will increase performance of cooking.

Tips for baking cake

- If the cake is too dry, increase the temperature by 10°C and decrease the cooking time.
- If the cake is wet, use less liquid or lower the temperature by 10°C.
- If the cake is too dark on top, place it on a lower rack, lower the temperature and increase the cooking time.
- If cooked well on the inside but sticky on the outside use less liquid, lower the temperature and increase the cooking time.

Tips for baking pastry

- If the pastry is too dry, increase the temperature by 10°C and decrease the cooking time. Dampen the layers of dough with a sauce composed of milk, oil, egg and yoghurt.
- If the pastry takes too long to bake, pay care that the thickness of the pastry you

have prepared does not exceed the depth of the tray.

- If the upper side of the pastry gets browned, but the lower part is not cooked, make sure that the amount of sauce you have used for the pastry is not too much at the bottom of the pastry. Try to scatter the sauce equally between the dough layers and on the top of pastry for an even browning.



Cook the pastry in accordance with the mode and temperature given in the cooking table. If the bottom part is still not browned enough, place it on one lower rack next time.

Tips for cooking vegetables

- If the vegetable dish runs out of juice and gets too dry, cook it in a pan with a lid instead of a tray. Closed vessels will preserve the juice of the dish.
- If a vegetable dish does not get cooked, boil the vegetables beforehand or

prepare them like canned food and put in the oven.

Ready meals functions

Selecting the ready meals functions



Ready Meals menu contains meal programmes that are prepared for you by professional cooks specially and stored in the memory of the control unit.

In this menu, temperature, rack position, weight and cooking functions are set automatically.



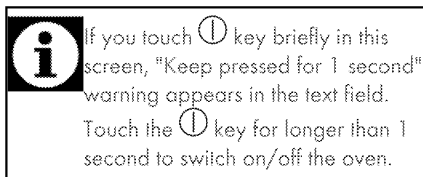





You can change the weight and cooking time according to your meal and your taste. To select the Ready Meals functions:

1. Touch  key to switch on the oven. Initial operation screen appears when the oven is turned on.



2. Touch  key to select the Ready Meals function display. In this step, "Cakes&bread&start" and the  symbol appears on the display.



3. Touch  keys to select the desired Ready Meals function main menu (Cakes&bread&start , Meat , Fish , Meat Poultry , Light meals , Special ).
4. Touch the  key to confirm the Main Meal menu you have selected.
5. Touch  keys to select the desired meal (Cookies, Cake, Small cake, etc).



6. Put your dish into the oven.

7. Touch  key to start cooking. "Cooking" appears on the display.

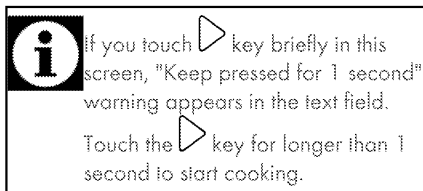

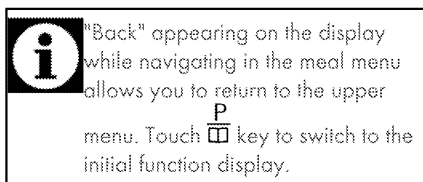
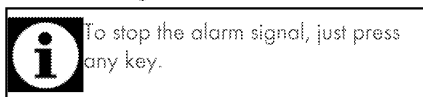

8. After the cooking is completed, "Good appetite..." appears on the display and alarm signal is heard.





Before starting to cook in the Ready Meals menu, you can set the weight depending on the meal type you have selected. To do this:

1. Touch  key after selecting the desired meal. "Weight" appears and the **kg** symbol flashes on the display.

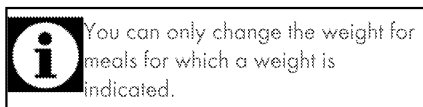
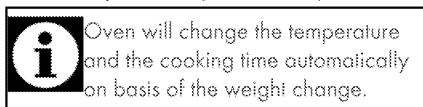

2. Touch  keys to set the weight and confirm by touching the  key.



3. Touch  key to start cooking.

Ready Meals menu:



May vary depending on the models

Cakes&breads&tarts	Meat	Fish	Meat poultry	Special meals	Special
Cookies	Meat loaf (lamb)	Fish fillet	Chicken baguette	Casserole	Fermenting
Cakes in cooking paper	Dalyan meatball	Baked anchovy	Chicken, fillet	Quiches	Home-made Yoghurt
Cheese cake	Roast beef	Haddock merlans		Macaroni cheese	Dried apple
Brownie		Salmon fillet		Lasagna	Fried chestnut
Sponge cake				Moussaka	
Apple strudel					
Apple pie					
Cinnamon rolls					



Settings menu

Brightness setting

Brightness can only be set when the oven is switched off.

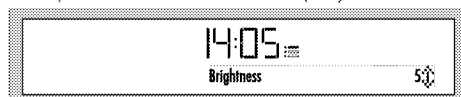
1. Touch  key with short intervals until "Brightness" appears on the display.  symbol flashes on the display.



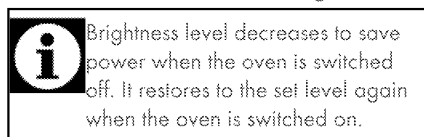

2. There are 5 brightness levels, namely 1, 2, 3, 4 and 5. Touch  keys to select the desired level.
3. Touch  to confirm the setting.





» It returns to the stand-by display. Only the current time appears on the display.

Voice Level setting

Voice level can only be set when the oven is switched off.

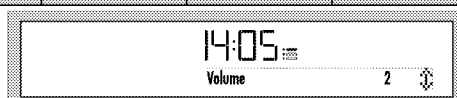

1. Touch  key with short intervals until "Voice Level" appears on the display.  symbol flashes on the display.





2. There are 2 voice levels, namely 1 and 2. Touch  keys to select the desired level.
3. Touch  to confirm the setting.
 - » It returns to the stand-by display. Only the current time appears on the display.

Language setting

Language can only be set when the oven is switched off.



1. Touch  key with short intervals until "Language" appears on the display.  symbol flashes on the display.





2. Touch  keys to select the desired language.
3. Touch  to confirm the setting.
 - » It returns to the stand-by display. Only the current time appears on the display.

Current time setting

Current time can only be set when the oven is switched off. If you want to change the time that was set during initial setup:

1. Touch  key with short intervals until "Day time" appears on the display. Hour field and  symbol flash on the display. Touch  keys to set the hour.



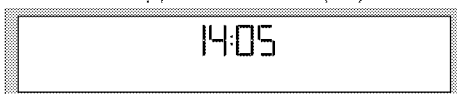

2. Touch  to confirm the hour.
 3. Minute field and  symbol flash on the display. Touch  keys to set the minute. Touch  to confirm the minute.
- > It returns to the stand-by display. Only the current time appears on the display.

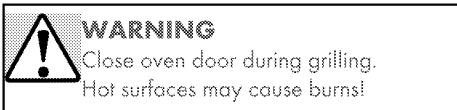

How to operate the grill



Switching on the grill





1. Touch  key to switch on the oven.
2. Touch  to select the desired grill function.

After the function is selected, "Temperature", "Cook time", "Cook end time" and "Booster" (rapid heating) can be set.

Grilling with electric grill

Food	Insertion level	Grilling time (approx.)
Fish	4..5	20...25 min. ^a
Sliced chicken	4..5	25...35 min.
Lamb chops	4..5	20...25 min.
Roast beef	4..5	25...30 min. ^a
Veal chops	4..5	25...30 min. ^a
Toast bread	4	1...2 min.

^a depending on thickness

3. If you want to change the temperature, touch  once to reach the temperature display.
4. Touch  until the desired temperature appears in the Temperature/Weight Indicator field. Touch  to set the temperature when the desired value appears on the display.
5. If cooking function, temperature and time values are suitable, touch  key to start cooking. Cooking starts and "Cooking" appears on the display.

Switching off the grill

1. Touch  key to switch off the oven.

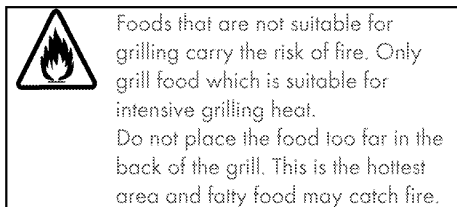

Cooking times table for grilling

How to operate the top oven

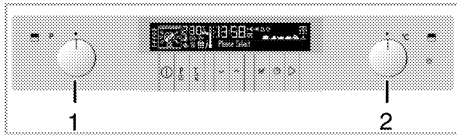

- 1 Top oven function knob
- 2 Top oven thermostat knob

Operating modes of the electric oven are selected with Function knob. Temperature setting is made with Thermostat knob. All oven functions are turned off by turning the relevant knob to Off (upper) position.

Select temperature and operating mode

1. Set the Thermostat knob to the desired temperature.
 2. Set the Function knob to the desired operating mode.
- » Oven heats up to the adjusted temperature and maintains it. During heating and cooling, thermostat light turns on.

Switching off the electric oven

Turn the Function knob and thermostat knob to Off (upper) position.

Operating modes

The order of operating modes shown here may be different from the arrangement on your product.

Top and bottom heating



Top and bottom heating are in operation. Food is heated simultaneously from the top and bottom. For example, it is suitable for cakes, pastries, or cakes and casseroles in baking moulds. Cook with one tray only.

Bottom heating



Only bottom heating is in operation. It is suitable for pizza and for subsequent browning of food from the bottom.

Low Grill



Small grill at the ceiling of the oven is in operation. Suitable for grilling and gratin dishes.

- Put small or medium-sized portions in correct rack position under the grill heater for grilling.
- Set the temperature to maximum level.

Turn the food after half of the grilling time.

Full grill



Large grill at the ceiling of the oven is in operation. It is suitable for grilling large amount of meat.

- Put big or medium-sized portions in correct rack position under the grill heater for grilling.
- Set the temperature to maximum level.
- Turn the food after half of the grilling time.

Cooking times table



The timings in this chart are meant as a guide. Timings may vary due to temperature of food, thickness, type and your own preference of cooking.



Maximum load capacity of oven tray:
4 kg (8.8 lb).



1st rack of the oven is the **bottom** rack.

- Do not place cookware with rough bases on the oven door.
- Ensure that there is at least 25mm space at top of oven when cooking larger foods or using taller cookware.

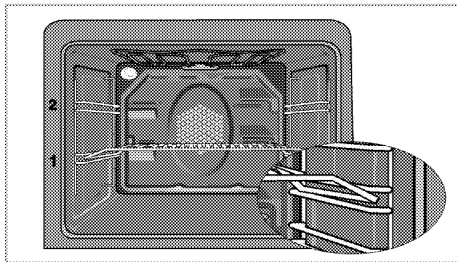

It is important to position the wire grill on the wire shelf correctly. The wire grill must be placed so that it will fit into the opening of the wire shelf as illustrated in the figure.

When removing tray from top oven, pull as shown in picture and hold with two hands from two sides.

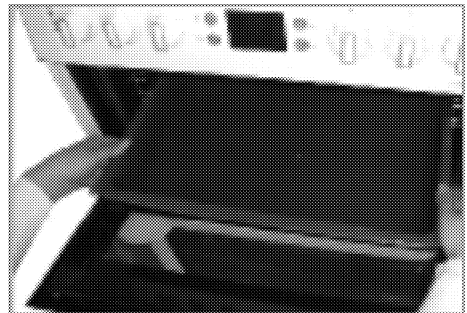
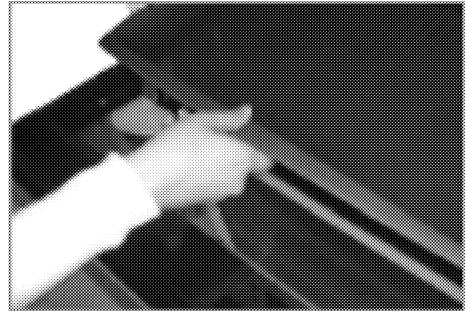

Baking and roasting



1st rack of the oven is the **bottom** rack.

Food	Cooking level number	Position	Rack position	Temperature (°C)	Cooking time (min.) (approx.)
Cake in tray	One level	<input type="checkbox"/>	2	175	25 ... 30
Cake in mould	One level	<input type="checkbox"/>	1	175	25 ... 30
Cakes in paper	One level	<input type="checkbox"/>	1	175	25 ... 30
Sponge cake	One level	<input type="checkbox"/>	2	200	5 ... 10
Cookies	One level	<input type="checkbox"/>	2	175	25 ... 30
Rough pastry	One level	<input type="checkbox"/>	2	200	35 ... 40
Filled savory pastry	One level	<input type="checkbox"/>	1	180	25 ... 35
Leaven	One level	<input type="checkbox"/>	1	190	35 ... 45
Lasagna	One level	<input type="checkbox"/>	1	180	30 ... 40
Pizza	One level	<input type="checkbox"/>	1	200	15 ... 20
	One level	<input type="checkbox"/>	1	200	10 ... 15
Beefsteak (whole)/Roast	One level	<input type="checkbox"/>	2	25 min. 250 after 180 ... 190	100 ... 120
Lamb haunch (casserole)	One level	<input type="checkbox"/>	2	25 min. 220 after 180 ... 190	70 ... 90
Roast chicken	One level	<input type="checkbox"/>	1	15 min. 250 after 190	55 ... 65
Fish	One level	<input type="checkbox"/>	2	200	20 ... 30

How to operate the top grill



WARNING

Close oven door during grilling.
Hot surfaces may cause burns!

Switching on the grill

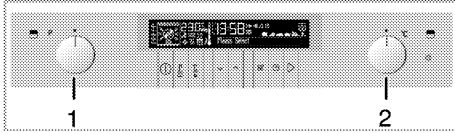

- 1 Top oven function knob
 - 2 Top oven thermostat knob
1. Set the Function knob to Grill symbol.
 2. Set the temperature to maximum level.
 3. If required, perform a preheating of about 5 minutes.
- » Thermostat (temperature) light turns on.

Switching off the grill

1. Turn the Grill control knob to Off (upper) position.
- * Put big or medium-sized portions in correct rack position under the grill heater for grilling.
 - * For food only whose top is required to be roasted, grill the food either by placing onto the wire grill in the tray or by placing the tray onto the floor of grilling compartment.

- * Food and plates placed onto the floor of grill compartment will get heated when the main oven is in use. Do not switch on the grill compartment when using it for storing food.

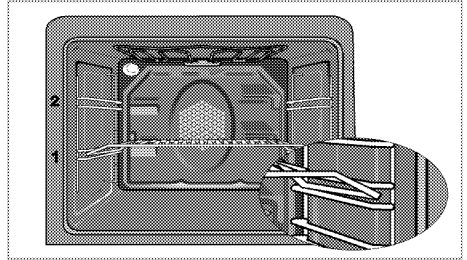

Foods that are not suitable for grilling carry the risk of fire. Only grill food which is suitable for intensive grilling heat.

Do not place the food too far in the back of the grill. This is the hottest area and fatty food may catch fire.

Top oven cooking times table for grilling

Grilling with electric grill



1st rack of the oven is the **bottom** rack.

Food	Insertion level	Grilling time (approx.)
Fish	1..2	20..25 min. [*]
Sliced chicken	1..2	25..35 min.
Lamb chops	1..2	20..25 min.
Roast beef	1..2	25..30 min. [*]
Veal chops	1..2	25..30 min. [*]
Toast bread	1..2	1..2 min.

^{*} depending on thickness

6 Maintenance and care

General information

Service life of the product will extend and the possibility of problems will decrease if the product is cleaned at regular intervals.



DANGER:

Disconnect the product from mains supply before starting maintenance and cleaning works.

There is the risk of electric shock!



DANGER:

Allow the product to cool down before you clean it.

Hot surfaces may cause burns!

- * Clean the product thoroughly after each use. In this way it will be possible to remove cooking residues more easily, thus avoiding these from burning the next time the appliance is used.
- * No special cleaning agents are required for cleaning the product. Use warm water with washing liquid, a soft cloth or sponge to clean the product and wipe it with a dry cloth.
- * Always ensure any excess liquid is thoroughly wiped off after cleaning and any spillage is immediately wiped dry.
- * Do not use cleaning agents that contain acid or chloride to clean the stainless or inox surfaces and the handle. Use a soft cloth with a liquid detergent (not abrasive) to wipe those parts clean, paying attention to sweep in one direction.



The surface might get damaged by some detergents or cleaning materials.

Do not use aggressive detergents, cleaning powders/creams or any sharp objects during cleaning.

Do not use harsh abrasive cleaners or sharp metal scrapers to clean the oven door glass since they can scratch the surface, which may result in shattering of the glass.



Do not use steam cleaners to clean the appliance as this may cause an electric shock.

Cleaning the control panel

Clean the control panel and knobs with a damp cloth and wipe them dry.



Do not remove the control buttons/knobs to clean the control panel.

Control panel may get damaged!

Cleaning the oven

To clean the side wall

1. Remove the front section of the side rack by pulling it in the opposite direction of the side wall.
2. Remove the side rack completely by pulling it towards you.

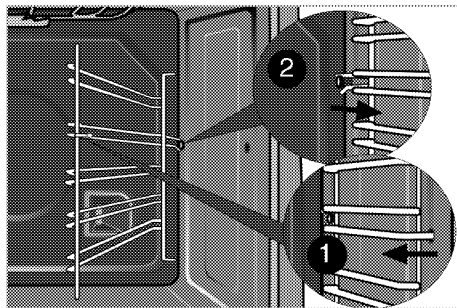

Catalytic walls

Side walls or just back wall of oven interior may be covered with catalytic enamel. The catalytic walls of the oven must not be cleaned. The porous surface of the walls is self-cleaning by absorbing and converting spitting fat (steam and carbon dioxide).

Clean oven door

To clean the oven door, use warm water with washing liquid, a soft cloth or sponge to clean the product and wipe it with a dry cloth.



Don't use any harsh abrasive cleaners or sharp metal scrapers for cleaning the oven door. They could scratch the surface and destroy the glass.



Front door inner glass is coated to easy clean material. Do not use any harsh abrasive cleaners, hard metal scrapers, scouring pads or bleach to clean front door inner glass as they may scratch the surface. This may destroy the coating material.

Removing the oven door

1. Open the front door (1).
2. Open the clips at the hinge housing (2) on the right and left hand sides of the front door by pressing them down as illustrated in the figure.

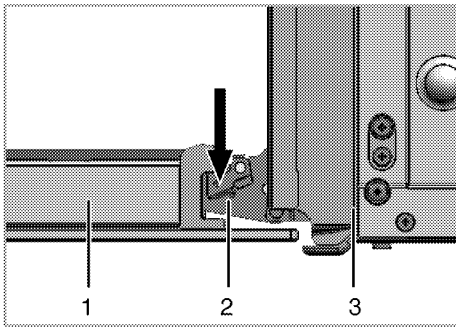

- 1 Front door
- 2 Hinge
- 3 Oven

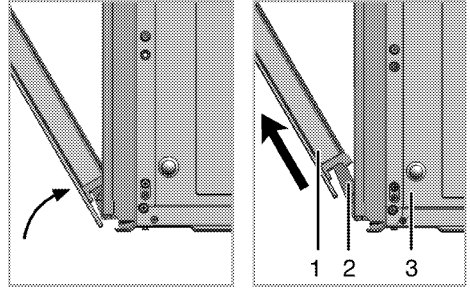

3. Move the front door to half-way.
4. Remove the front door by pulling it upwards to release it from the right and left hinges.



Steps carried out during removing process should be performed in reverse order to install the door. Do not forget to close the clips at the hinge housing when reinstalling the door.

Removing the door inner glass

The entire inner glass panel of the oven door can be removed for cleaning.

Open the oven door.

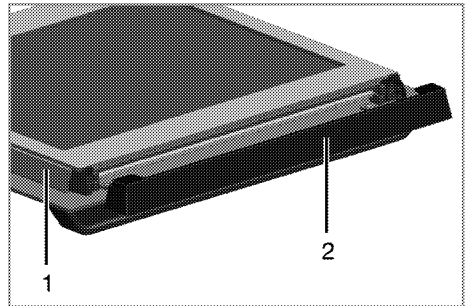

- 1 Frame
- 2 Plastic part

Pull towards yourself and remove the plastic part installed to upper section of the front door.

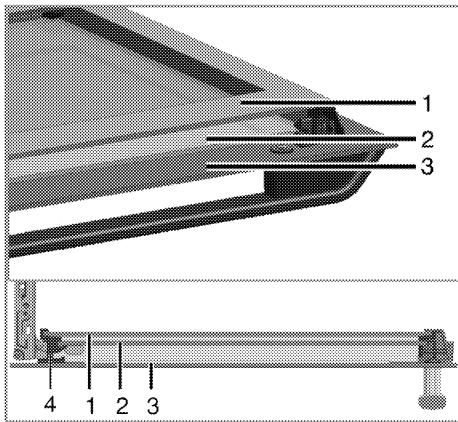

- 1 Innermost glass panel
- 2 Inner glass panel
- 3 Outer glass panel
- 4 Plastic glass panel slot-Lower

As illustrated in figure, raise the innermost glass panel (1) slightly in direction **A** and pull it out in direction **B**.

Repeat the same procedure to remove the inner glass panel (2).

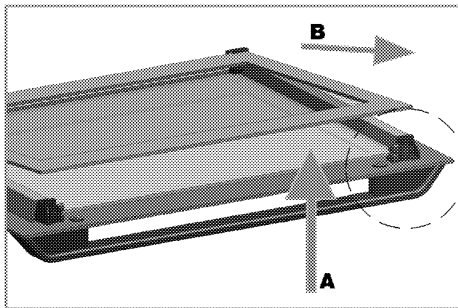

The first step to regroup the door is reinstalling inner glass panel (2).

As illustrated in figure, place the chamfered corner of the glass panel so that it will rest in the chamfered corner of the plastic slot.

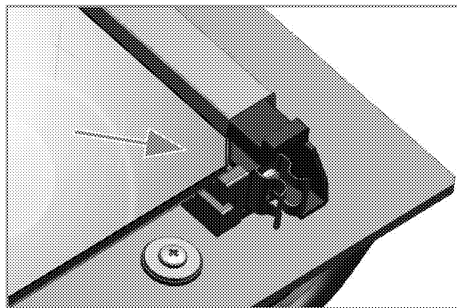

Inner glass panel (2) must be installed into the plastic slot close the innermost glass panel (1).

When installing the innermost glass panel (1), make sure that the printed side of the panel faces towards the inner glass panel.

It is important to seat corner of inner glass panel into the lower plastic slot.

Push the plastic part towards the frame until you hear a "click".

Removing the top oven door inner glass

The inner glass panel of the oven door can be removed for cleaning.

Open the oven door.

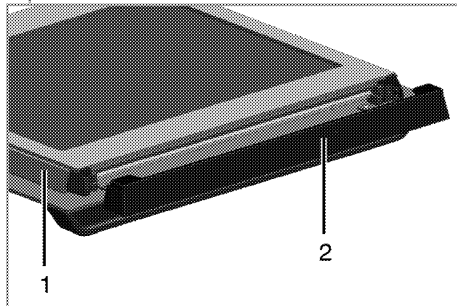

- 1 Frame
- 2 Plastic part

Pull towards yourself and remove the plastic part installed to upper section of the front door.

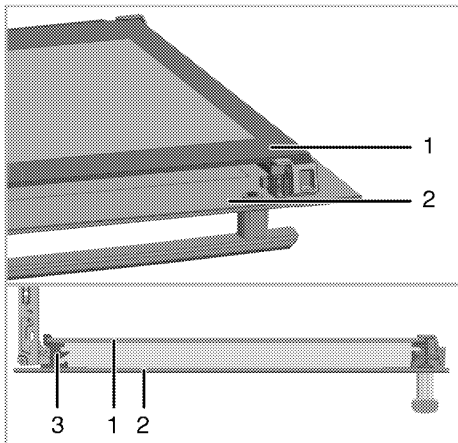

- 1 Inner glass panel
- 2 Outer glass panel
- 3 Plastic glass panel slot-Lower

As illustrated in figure, raise the innermost glass panel (1) slightly in direction **A** and pull it out in direction **B**.

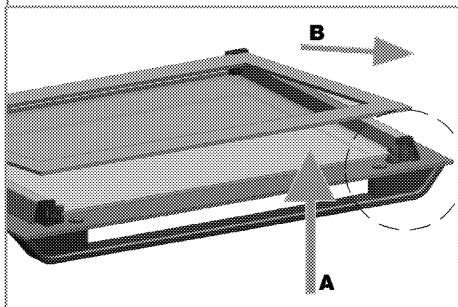

When installing the inner glass panel (1), make sure that the printed side of the panel faces towards the inner.

It is important to seat lower corner of inner glass panel into the lower plastic slot. Push the plastic part towards the frame until you hear a "click".

Replacing the oven lamp



DANGER:

Before replacing the oven lamp, make sure that the product is disconnected from mains and cooled down in order to avoid the risk of an electrical shock. Hot surfaces may cause burns!



The oven lamp is a special electric light bulb that can resist up to 300 °C. See *Technical specifications, page 11* for details. Oven lamps can be obtained from Authorised Service Agents or technician with licence.



Position of lamp might vary from the figure.

If your oven is equipped with a round lamp:

1. Disconnect the product from mains.
2. Turn the glass cover counter clockwise to remove it.

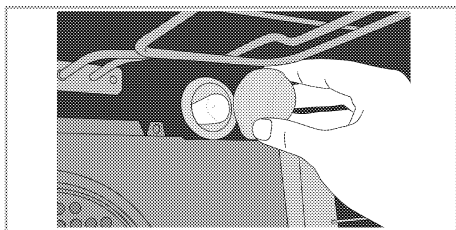

3. Pull out the oven lamp from its socket and replace it with the new one.
4. Install the glass cover.

If your oven is equipped with a square lamp:

1. Disconnect the product from mains.
2. Remove the wire racks as described. See *Cleaning the oven*, page 35.

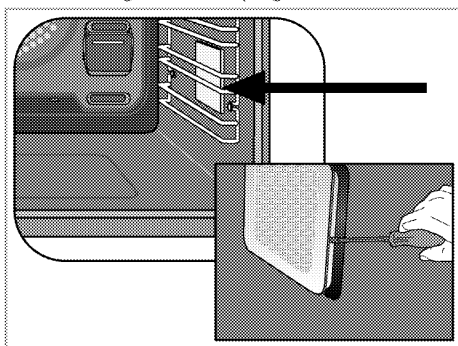

3. Remove the protective glass cover with a screwdriver.
4. Pull out oven lamp and replace it with new one.
5. Install the glass cover and then the wire racks.

7 Troubleshooting

Oven emits steam when it is in use.

- * It is normal that steam escapes during operation. >>> *This is not a fault.*

Product emits metal noises while heating and cooling.

- * When the metal parts are heated, they may expand and cause noise. >>> *This is not a fault.*

Product does not operate.

- * The mains fuse is defective or has tripped. >>> *Check fuses in the fuse box. If necessary, replace or reset them.*
- * Product is not plugged into the (grounded) socket. >>> *Check the plug connection.*
- * Buttons/knobs/keys on the control panel do not function. >>> *Keylock may be enabled. Please disable it. (See.)*

Oven light does not work.

- * Oven lamp is defective. >>> *Replace oven lamp.*
- * Power is cut. >>> *Check if there is power. Check the fuses in the fuse box. If necessary, replace or reset the fuses.*

Oven does not heat.

- * Function and/or Temperature are not set. >>> *Set the function and the temperature with the Function and/or Temperature knob/key.*
- * Power is cut. >>> *Check if there is power. Check the fuses in the fuse box. If necessary, replace or reset the fuses.*



Consult the Authorised Service Agent or technician with licence or the dealer where you have purchased the product if you can not remedy the trouble although you have implemented the instructions in this section. Never attempt to repair a defective product yourself.

8 Guarantee

Guarantee for Refrigeration, Cooking Appliances, Washing Machines & Dishwashers

Your new Grundig product is guaranteed against the cost of breakdown repairs for 5 years from the date of the original purchase.

"Please visit the "support" section on the Grundig website at www.grundig.co.uk to register your 5 year warranty."

What is covered?

- * Repairs necessary as a result of faulty materials, defective components or manufacturing defect.
- * The cost of functional replacement parts, but excluding consumable items.
- * The labour costs of a Grundig approved repairer to carry out the repair.

What is not covered?

- * Transit, delivery or accidental damage or misuse and abuse.
- * Cabinet or appearance parts, including knobs, flaps, handles or container lids.
- * Accessories or consumable items including but not limited to, ice trays, scrapers, cutlery baskets, filters and light bulbs.
- * Repairs required as a result of unauthorised repair or inexperienced installation that fails to meet the requirements contained in the user instruction book.
- * Repairs to products used on commercial or non-residential household premises.
- * Loss of frozen food in freezers or fridge/freezers. (Food loss insurance is often included within your household contents insurance policy, or may be available separately from your retailer.)

Important notes

- * Your Grundig product is designed and built for domestic household use only.
- * The guarantee will be void if the product is installed or used in commercial or non-residential domestic household premises.
- * The product must be correctly installed, located and operated in accordance with the instructions contained in the User Instructions Booklet provided.
- * Professional installation by a qualified Electrical Domestic Appliance Installer is recommended for all Washing Machines, Dishwashers and Electric Cookers
- * Gas Cookers must only be installed by a Gas Safe (or BORD GAIS) registered Gas Installer.
- * The guarantee is given only within the boundaries of the United Kingdom and the Republic of Ireland.
- * The guarantee is applicable only to new products and is not transferable if the product is resold.
- * Grundig disclaims any liability for incidental or consequential damages.
- * The guarantee does not in anyway diminish your statutory or legal rights.

Should you experience any difficulty in obtaining service please contact the Grundig Customer Helpline.

Tel: 0845 603 1234

0345 603 1234

e-mail: service@Grundig.co.uk

9 Service

Please keep your purchase receipt or other proof of purchase in a safe place; you will need to have it should the product require attention under guarantee.

You should also complete the details below; it will help us assist you when requesting service. (The model number is printed on the Instruction Booklet and the serial number is printed on the Rating Label affixed to the appliance)

Model No:

Serial No:

Retailer:

Date of purchase:

For service under guarantee simply telephone the appropriate number below UK Mainland & Northern Ireland

0845 603 1234

0345 603 1234

Republic of Ireland

All Refrigeration, All Cookers

Washing Machines and Dishwashers

01 862 3411

Before requesting service please check the trouble-shooting guide in the Operating Instructions as a charge may be levied where no fault is found even though your product may still be under guarantee. Service once the manufacturers guarantee has expired.

If you have purchased an extended guarantee please refer to the instructions contained within the extended guarantee agreement document. Otherwise please call the appropriate number above where service can be obtained at a charge.

Grundig, 1 Greenhill Crescent, Watford Herts WD18 8QU

FOR A GOOD REASON
GRUNDIG

285.4443.83/R.AB/30.06.2015